

CK/CP DN 12÷15



DUALBLOCK® PNEUMATICALLY
ACTUATED COMPACT DIAPHRAGM
VALVE



CK/CP DN 12÷15

The new CK/CP valve represents the evolution of the CM/CP series, offering greater reliability, durability, and versatility. Designed for demanding industrial applications, it combines compactness, lightness, and high performance, ensuring safe and long-lasting operation even in challenging environments.



DUALBLOCK® PNEUMATICALLY ACTUATED COMPACT DIAPHRAGM VALVE

- Valve body with union connection (PVC-U, PVC-C, PP-H, PVDF)
- No metal parts in contact with the fluid nor with the environment
- DualBlock® safety device to prevent self-unscrewing of the actuator nut
- Sealed optical position indicator
- Air inlets orientable every 90°
- Diaphragm seal fully embedded into the valve body
- Circular rib integrated into the valve body enhancing the effectiveness of the external sealing system
- Compatible with a wide range of chemicals (check on our [Chemical Compatibility Guide - https://www.aliaxis.it/en/tools-and-services/guide-to-chemical-compatibilities](https://www.aliaxis.it/en/tools-and-services/guide-to-chemical-compatibilities))
- Suitable for industrial applications, dosing and sampling
- Compact and lightweight design
- Easy installation in tight spaces
- Average 10% increase flow capacity compared to the previous version

Technical specifications - CK

Construction	Pneumatically operated 2 way compact diaphragm valve
Size range	DN 12 ÷ 15
Nominal pressure	PN 6 with water at 20 °C
Temperature range	PVC-U: 0 °C ÷ 60 °C PVC-C: 0 °C ÷ 100 °C PP-H: 0 °C ÷ 100 °C PVDF: -20°C - 140°C
PVC-U coupling standards	Solvent welding: EN ISO 1452, EN ISO 15493. Can be coupled to pipes according to EN ISO 1452, EN ISO 15493, DIN 8062. Thread: ISO 228-1, DIN 2999
PVC-C coupling standards	Solvent welding: EN ISO 15493. Can be coupled to pipes according to EN ISO 15493 Thread: ISO 228-1, DIN 2999
PP-H coupling standards	Solvent welding: EN ISO 15494. Can be coupled to pipes according to EN ISO 15494. Thread: ISO 228-1, DIN 2999
PVDF coupling standards	Solvent welding: EN ISO 10931. Can be coupled to pipes according to EN ISO 10931.

Technical specifications - CK

Reference standards	PVC-U construction criteria: EN ISO 16138, EN ISO 1452, EN ISO 15493 PVC-C construction criteria: EN ISO 16138, EN ISO 15493 PP-H construction criteria: EN ISO 16138, EN ISO 15494 PVDF construction criteria: EN ISO 16138, EN ISO 10931 Test methods and requirements: ISO 9393 PVC-U/PVC-C installation criteria: DVS 2204, DVS 2221, UNI 11242 PP-H installation criteria: EN 14728, DVS 2207-11, DVS 2208-1, UNI 11318 PVDF installation criteria: EN 14728, DVS 2207-15, DVS 2208-1
Valve body materials	PVC-U / PVC-C / PP-H / PVDF
Diaphragm materials	EPDM, PTFE/EPDM (FKM and NBR on request)

The new compact and light piston actuator in PP-GR makes the CK/CP the ideal choice for applications requiring very frequent valve operation and a long valve lifetime.

Technical specifications - Pneumatic actuator

Construction	Single-acting (NC-NO) and Double-acting (DA)* pneumatic piston actuator
Actuator material	Body: PP-GR Optical position indicator: PP
Control air pressure	Minimum: according to working pressure and actuator function (see graphs) Maximum: NC: 6 bar - DA: 5 bar - NO: max 6 bar
Control medium	Inert gases
Control medium temperature	Max 40 °C
Standard equipment	Optical position indicator
Accessories	Pilot solenoid valves 3-5/2 ways for direct or manifold mounting

(*) Double Acting function available on request

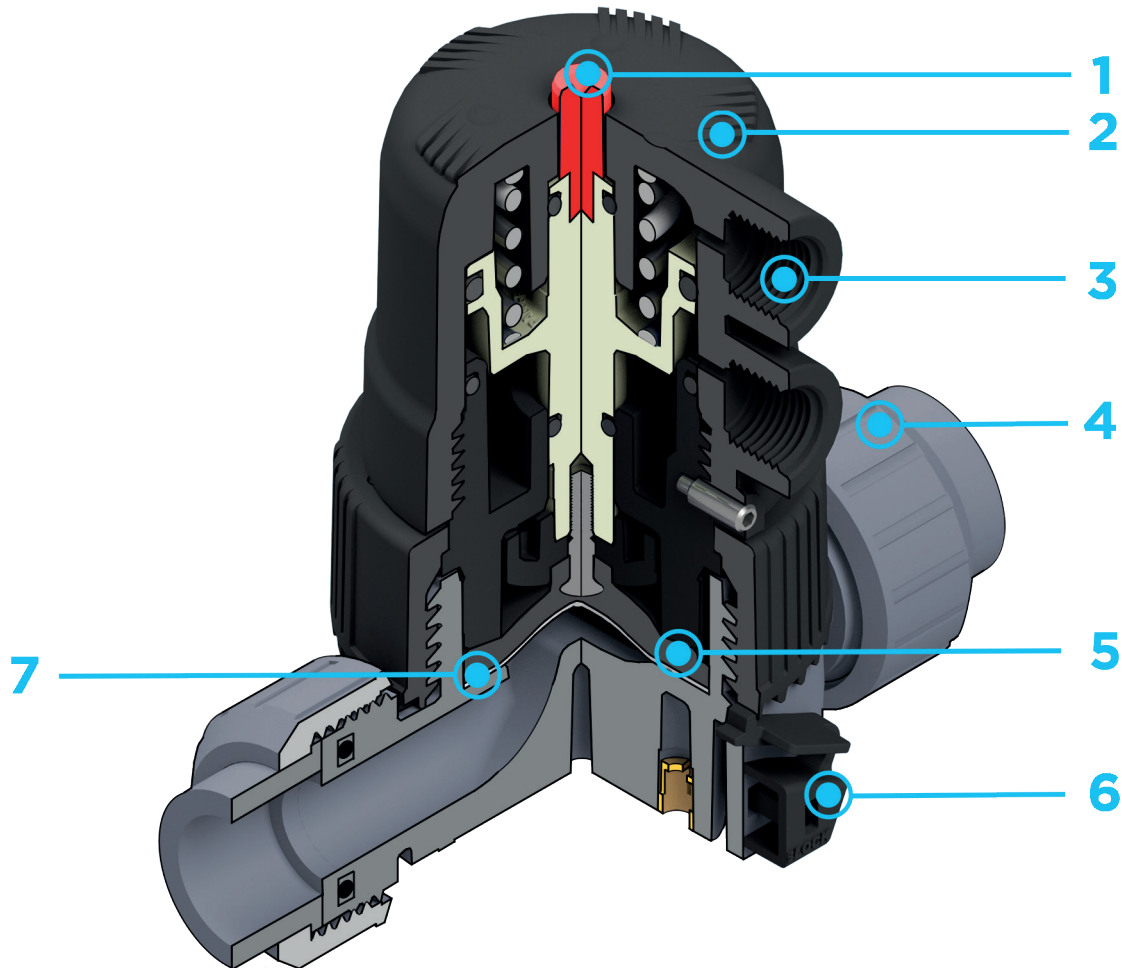

1 High-visibility sealed position indicator for immediate and accurate visual feedback on valve status, enhancing operational safety and control.

2 Compact and lightweight piston-type PP-GR actuator equipped with an anti-unscrewing system that prevents piston rotation. This design minimizes diaphragm distortion, extends service life, and ensures maintenance-free operation.

3 90° adjustable compressed air inlets allow flexible alignment with

pipeline connections or specific plant configurations, simplifying installation and integration.

4 Unionized valve bodies available in PVC-U, PVC-C, PP-H, and PVDF, fully interchangeable with the previous CM/CP series. Designed according to EN-558 standards for dimensional compatibility and easy retrofitting.

5 Diaphragm seal fully embedded within the valve body, ensuring optimal rubber compression without lateral expansion. This design enhances sealing

performance, reduces wear, and improves long-term reliability.

6 DualBlock® safety device prevents self-unscrewing of the actuator nut, ensuring secure and reliable operation even under dynamic process conditions.

7 Circular rib integrated into the valve body enhances the diaphragm sealing system by promoting outward compression. This design maximizes sealing efficiency and reduces the risk of leakage under pressure.

TECHNICAL DATA

PRESSURE VARIATION ACCORDING TO TEMPERATURE

PVC-U BODY

For water and non-hazardous fluids with regard to which the material is classified as CHEMICALLY RESISTANT. In other cases, a reduction of the nominal pressure PN is required (25 years with safety factor).

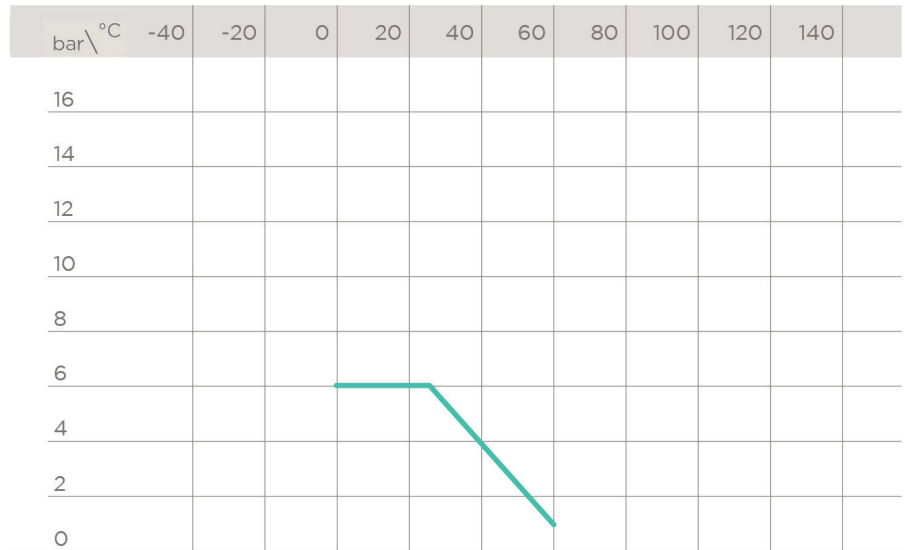

C-PVC BODY



PP-H BODY



PVDF BODY



CONTROL PRESSURE ACCORDING TO CK/CP NC WORKING PRESSURE

Minimum control pressure (Y axis) according to working pressure (X axis) with PTFE/EPDM diaphragm.

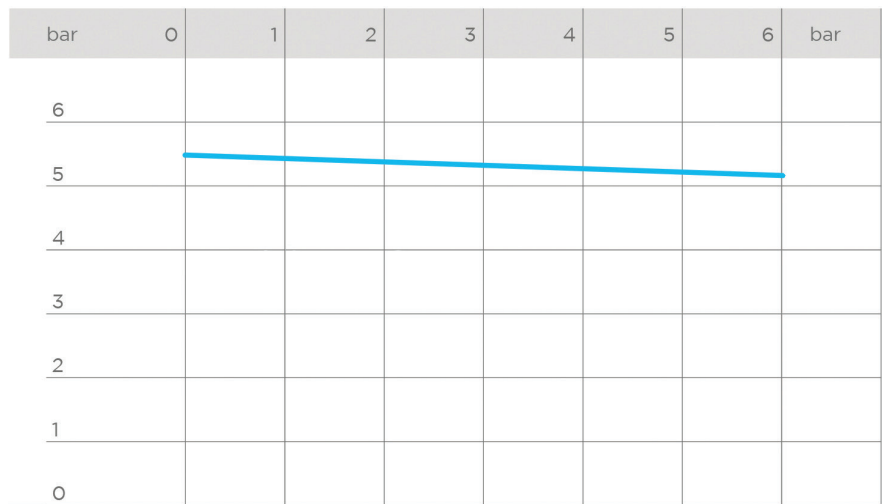

CONTROL PRESSURE ACCORDING TO CK/CP NO WORKING PRESSURE

Minimum control pressure (Y axis) according to working pressure (X axis) with PTFE/EPDM diaphragm.

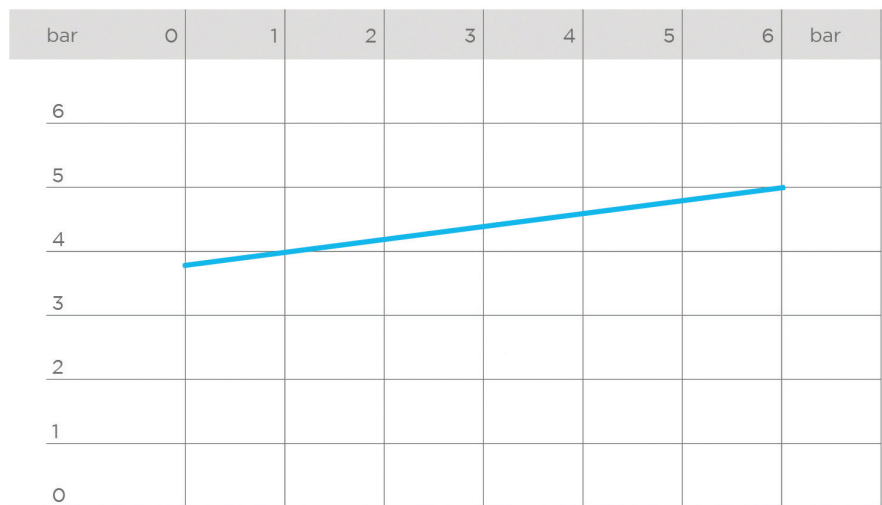

CONTROL PRESSURE ACCORDING TO CK/CP DA WORKING PRESSURE

Minimum control pressure (Y axis) according to working pressure (X axis) with PTFE/EPDM diaphragm.

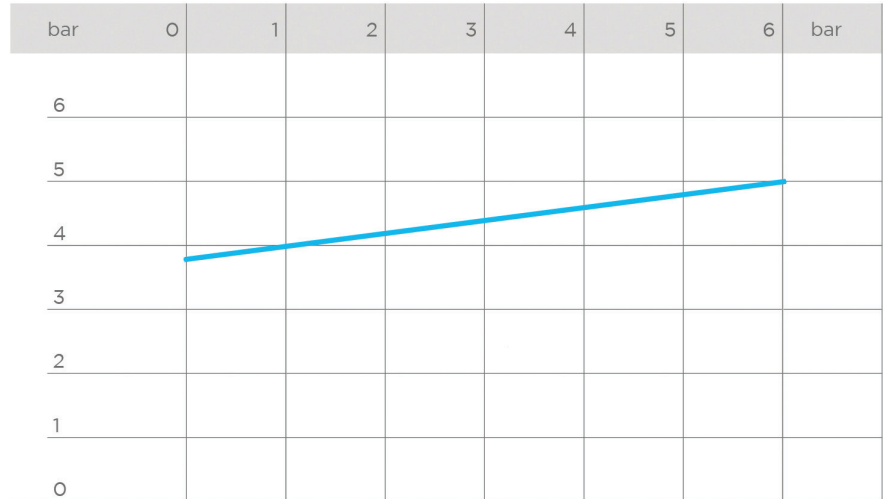

PRESSURE DROP GRAPH

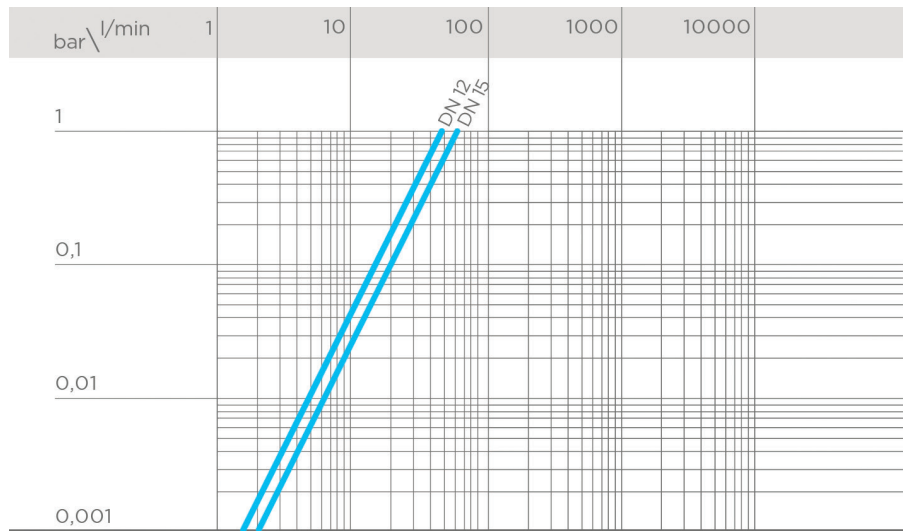

K_v100 FLOW COEFFICIENT

The K_v100 flow coefficient is the Q flow of litres per minute of water at a temperature of 20°C that will generate Δp= 1 bar pressure drop at a certain valve position.

The K_v100 values shown in the table are calculated with the valve completely open.

DN	12	15
Kv100 l/min	51	61

PNEUMATIC ACTUATED DATA

FUNCTIONAL CHARACTERISTICS

Function type	Double-acting	Normally closed (NC)	Normally Open (NO)
Valve opening	air	air	spring
Valve closing	air	spring	air

ACTUATOR CAPACITY

Air consumption per complete valve cycle measured at atmospheric pressure (1 atm, 0°C).
Unit: NL/cycle (Normal Litres per cycle).

DN	15	20
NC	0,036 NL	0,036 NL
NO	0,036 NL	0,036 NL
DA	0,072 NL	0,072 NL

COMPRESSED AIR CONNECTIONS

Function type	Double-acting (DA)	Normally closed (NC)	Normally Open (NO)
Valve opening	Inlet B	Inlet B	-
Valve closing	Inlet A	-	Inlet A

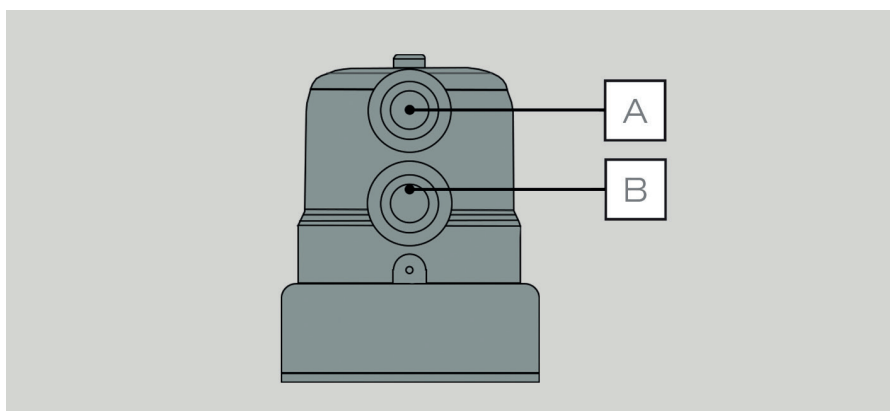

DIMENSIONS

CK/CP DN 12÷15 PVC-U

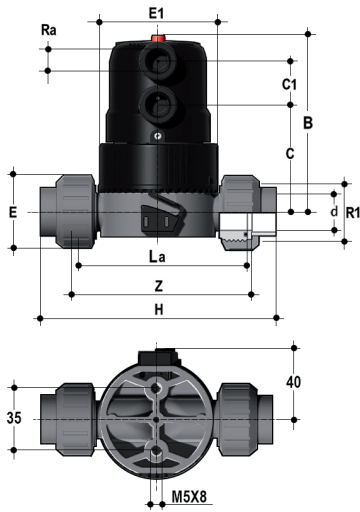

CKUIV/CP NC

Compact diaphragm valve with female metric series union ends for solvent welding, pneumatically actuated, Normally Closed function

d	DN	PN	B	C	C ₁	E	E ₁	H	L ₃	R ₁	R ₂	Z	g	EPDM code	PTFE code
20	15	6	97	59	24	41	66	129,5	90	1"	G 1/4"	97,5	355	CKUIVNC020E	CKUIVNC020P

* FKM on request - Double Acting function on request)

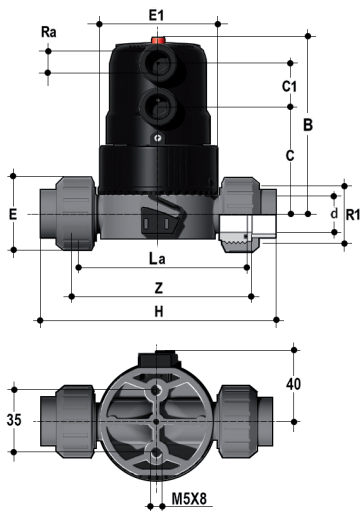

CKUIV/CP NO

Compact diaphragm valve with female metric series union ends for solvent welding, pneumatically actuated, Normally Open function

d	DN	PN	B	C	C ₁	E	E ₁	H	L ₃	R ₁	R ₂	Z	g	EPDM code	PTFE code
20	15	6	97	59	24	41	66	129,5	90	1"	G 1/4"	97,5	335	CKUIVNO020E	CKUIVNO020P

* FKM on request - Double Acting function on request)

DIMENSIONS

CK/CP DN 12÷15 PVC-U

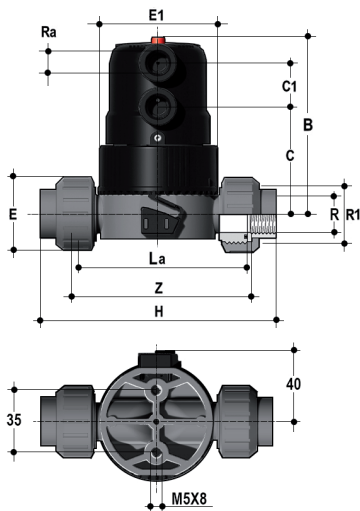

CKUFV/CP NC

Compact diaphragm valve with BSP threaded female union ends, pneumatically actuated, Normally Closed function

R	DN	PN	B	C	C ₁	E	E ₁	H	L ₂	R ₁	R ₂	Z	g	EPDM code	PTFE code
3/8"	12	6	97	59	24	41	66	128	90	1"	G 1/4"	104	360	CKUFVNC038E	CKUFVNC038P
1/2"	15	6	97	59	24	41	66	129,5	90	1"	G 1/4"	97,5	355	CKUFVNC012E	CKUFVNC012P

* FKM on request - Double Acting function on request)

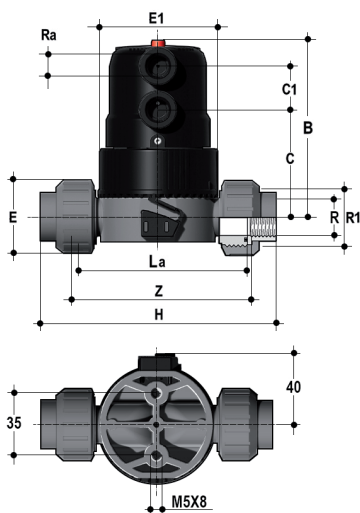

CKUFV/CP NO

Compact diaphragm valve with BSP threaded female union ends, pneumatically actuated, Normally Open function

R	DN	PN	B	C	C ₁	E	E ₁	H	L ₂	R ₁	R ₂	Z	g	EPDM code	PTFE code
3/8"	12	6	97	59	24	41	66	128	90	1"	G 1/4"	104	340	CKUFVNO038E	CKUFVNO038P
1/2"	15	6	97	59	24	41	66	129,5	90	1"	G 1/4"	97,5	335	CKUFVNO012E	CKUFVNO012P

* FKM on request - Double Acting function on request)

DIMENSIONS

CK/CP DN 12÷15 PVC-C

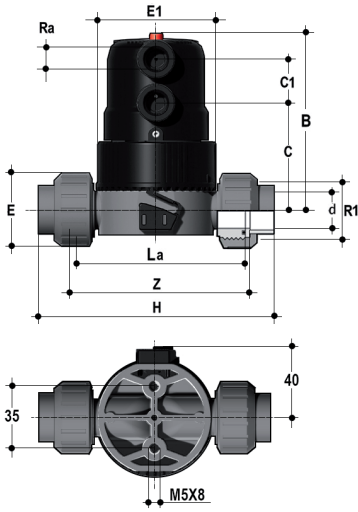

CKUIC/CP NC

Compact diaphragm valve with female metric series union ends for solvent welding, pneumatically actuated, Normally Closed function

d	DN	PN	B	C	C ₁	E	E ₁	H	L ₃	R ₁	R ₂	Z	g	EPDM code	PTFE code
20	15	6	97	59	24	41	66	129,5	90	1"	G 1/4"	97,5	355	CKUICNC020E	CKUICNC020P

* FKM on request - Double Acting function on request)

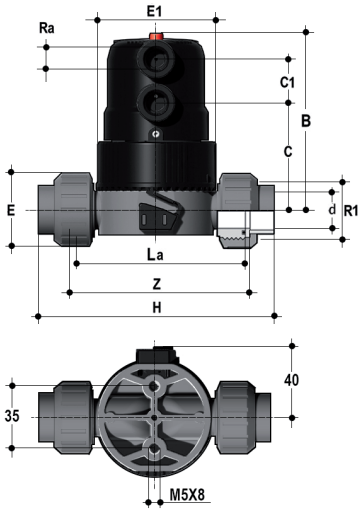

CKUIC/CP NO

Compact diaphragm valve with female metric series union ends for solvent welding, pneumatically actuated, Normally Open function

d	DN	PN	B	C	C ₁	E	E ₁	H	L ₃	R ₁	R ₂	Z	g	EPDM code	PTFE code
20	15	6	97	59	24	41	66	129,5	90	1"	G 1/4"	97,5	335	CKUICNO020E	CKUICNO020P

* FKM on request - Double Acting function on request)

DIMENSIONS

CK/CP DN 12÷15 PP-H

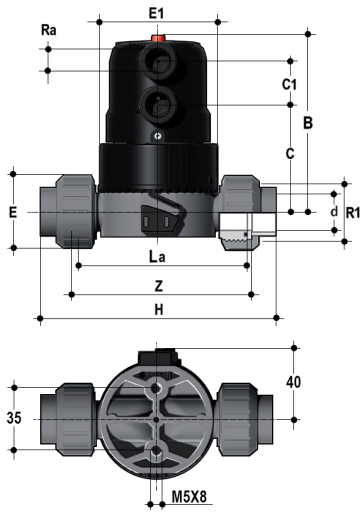

CKUIM/CP NC

Compact diaphragm valve with female metric series union ends for socket welding, pneumatically actuated, Normally Closed function

d	DN	PN	B	C	C ₁	E	E ₁	H	L ₂	R ₁	R ₂	Z	g	EPDM code	PTFE code
20	15	6	97	59	24	47,5	66	130	90	1"	G 1/4"	98	325	CKUIMNC020E	CKUIMNC020P

* FKM on request - Double Acting function on request)

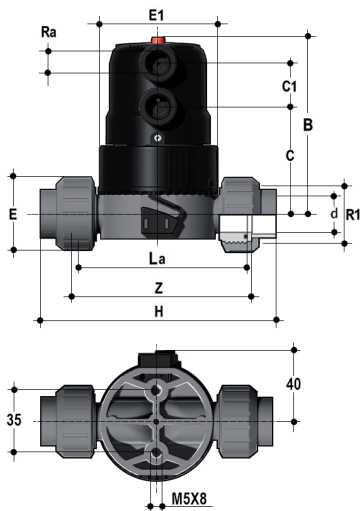

CKUIM/CP NO

Compact diaphragm valve with female metric series union ends for socket welding, pneumatically actuated, Normally Open function

d	DN	PN	B	C	C ₁	E	E ₁	H	L ₂	R ₁	R ₂	Z	g	EPDM code	PTFE code
20	15	6	97	59	24	47,5	66	130	90	1"	G 1/4"	98	305	CKUIMNO020E	CKUIMNO020E

* FKM on request - Double Acting function on request)

DIMENSIONS

CK/CP DN 12÷15 PP-H

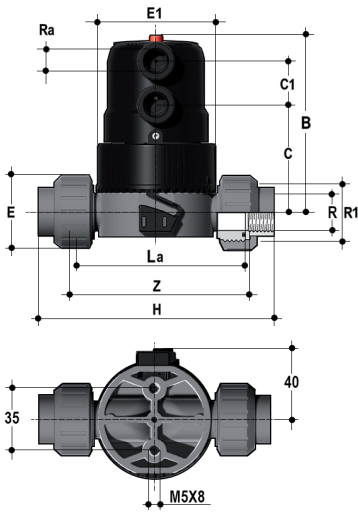

CKUFM/CP NC

Compact diaphragm valve with BSP threaded female union ends, pneumatically actuated, Normally Closed function

R	DN	PN	B	C	C ₁	E	E ₁	H	L ₀	R ₁	R ₂	Z	g	EPDM code	PTFE code
3/8"	12	6	97	59	24	47,5	66	128	90	1"	G 1/4"	104	330	CKUFMNC038E	CKUFMNC038P
1/2"	15	6	97	59	24	47,5	66	129,5	90	1"	G 1/4"	97,5	325	CKUFMNC012E	CKUFMNC012P

* FKM on request - Double Acting function on request)

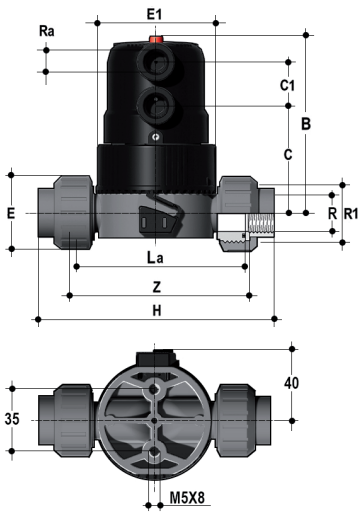

CKUFM/CP NO

Compact diaphragm valve with BSP threaded female union ends, pneumatically actuated, Normally Open function

R	DN	PN	B	C	C ₁	E	E ₁	H	L ₀	R ₁	R ₂	Z	g	EPDM code	PTFE code
3/8"	12	6	97	59	24	47,5	66	128	90	1"	G 1/4"	104	310	CKUFMNO038E	CKUFMNO038P
1/2"	15	6	97	59	24	47,5	66	129,5	90	1"	G 1/4"	97,5	305	CKUFMNO012E	CKUFMNO012P

* FKM on request - Double Acting function on request)

DIMENSIONS

CK/CP DN 12÷15 PVDF

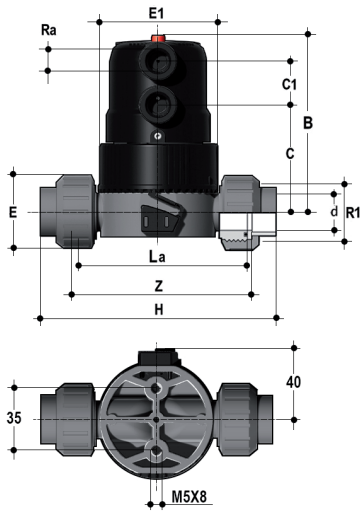

CKUIF/CP NC

Compact diaphragm valve with female metric series union ends for socket welding, pneumatically actuated, Normally Closed function

d	DN	PN	B	C	C ₁	E	E ₁	H	L ₀	R ₁	R ₀	Z	g	PTFE code
20	15	6	97	59	24	47,5	66	129,5	90	1"	G 1/4"	97,5	385	CKUIFNC020P

* FKM on request - Double Acting function on request)

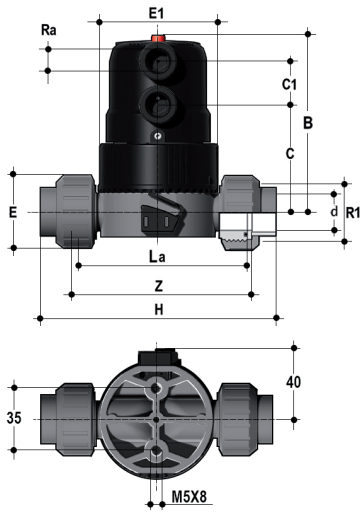

CKUIF/CP NO

Compact diaphragm valve with female metric series union ends for socket welding, pneumatically actuated, Normally Open function

d	DN	PN	B	C	C ₁	E	E ₁	H	L ₀	R ₁	R ₀	Z	g	PTFE code
20	15	6	97	59	24	47,5	66	129,5	90	1"	G 1/4"	97,5	365	CKUIFNO020P

* FKM on request - Double Acting function on request)

COMPONENTS

EXPLODED VIEW

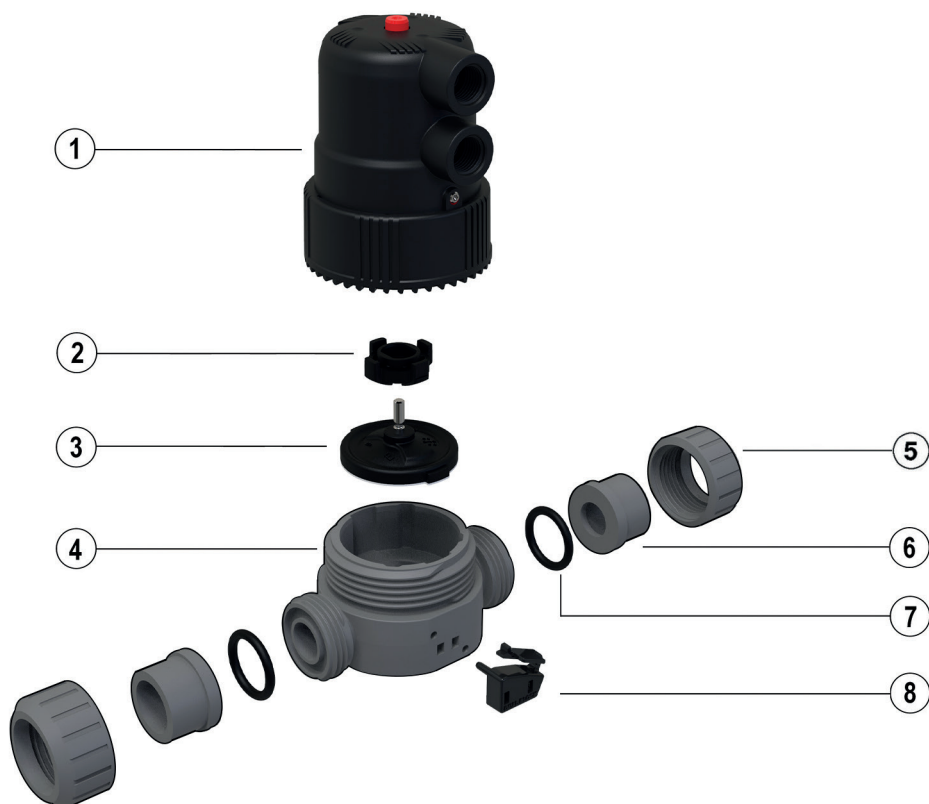

1 Actuator (PP-GR - 1)*

2 Compressor (PA-MXD6 - 1)*

3 Seal diaphragm (EPDM, PTFE - 1)*
- FKM on request

4 Valve body (PVC-U, PVC-C, PP-H,
PVDF - 1)*

5 Union nut (PVC-U, PVC-C, PP-H,
PVDF - 2)*

6 End connector (PVC-U, PVC-C,
PP-H, PVDF - 2)*

7 Socket seal O-Ring (EPDM, FKM
- 2)*

8 DualBlock® (POM - 1)*

* Spare parts

The material the component is made of and the quantity supplied are shown in brackets

DISASSEMBLY

- 1) Depressurise the section of the system where the valve is installed and drain the pipeline upstream and downstream of the valve.
- 2) Remove the valve from the system by unscrewing the two union nuts (5), taking care to ensure that the sealing O-rings (7) remain properly seated in their housings and do not come out.
- 3) Unscrew the connection nut between the actuator (1) and the valve body (4) using a strap wrench or another suitable tool that does not damage the surface. Before proceeding, release the DualBlock® device to allow rotation of the connection nut. **Note:** For valves with Normally Closed (NC) function, this operation is easier if the actuator is pressurized and the valve is in the open position.
- 4) Disconnect the valve from the compressed air supply and, if applicable, from the electrical network.
- 5) Separate the valve body (4) from the pneumatic actuator (1).
- 6) Unscrew the diaphragm (3) and remove the compressor (2).

Safety Warnings

All disassembly, reassembly, installation, and maintenance operations must be carried out exclusively by qualified and authorized personnel, in accordance with company procedures and applicable regulations.

ASSEMBLY

- 1) Insert the compressor (2) onto the actuator rod (1).
- 2) Screw the diaphragm (3) fully to the end of the thread. Then continue tightening beyond the initial point of resistance until the diaphragm is correctly aligned with the internal seats of the valve body (see Fig. 1). **Note:** At this stage, it is possible to adjust the orientation of the compressed air connections to align them with the piping, if needed, to facilitate installation in confined spaces (see fig. 2).
- 3) Check the correct positioning of the DualBlock® device and reassemble the actuator (1) onto the valve body (4) by screwing the connection nut (8) using a strap wrench or another suitable tool that does not damage its surface.
- 4) Check proper tightening by verifying that the reference mark on the connection nut is precisely positioned between the two alignment notches on the valve body (see fig. 3).
- 5) Reinstall the valve on the system following the instructions in the INSTALLATION section.
- 6) Restore connections to compressed air and the electrical network (if present).



Safety Warnings

Ensure all components are clean and undamaged. Replace any worn parts if necessary.

Note: All operations on equipment under pressure or containing compressed springs must be carried out under safe conditions for the operator.

Fig. 1



Fig. 2



Fig. 3

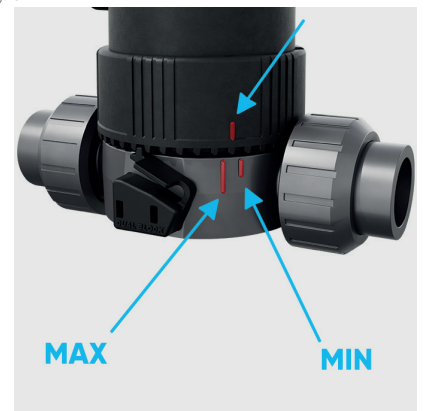

INSTALLATION

The valve can be installed in any orientation and flow direction. Before proceeding with installation, carefully follow the steps below to ensure proper assembly and safe operation.

Installation Procedure

- 1) Ensure that the pipes to be connected are properly aligned. Misalignment can cause mechanical stress on the valve body and joints, leading to premature failure or leakage.
- 2) Unscrew the union nuts (5) from the valve body and slide them onto the pipe ends. Ensure the nuts are oriented correctly for reassembly.
- 3) Join the end connectors (6) to the pipe using the appropriate method for the material and connection type (e.g., solvent welding, socket welding, butt fusion, or threading), strictly following the recommended procedures and parameters for each technique.
- 4) Place the valve body between the end connectors (6). Ensure that the O-rings (7) are correctly seated in their grooves and are not twisted or displaced.
- 5) Hand-tighten the union nuts (5) evenly, then use a suitable tool to tighten further without over-torquing. Over-tightening may damage the threads or deform the valve body.
- 6) Connect the compressed air supply as described in the section "Compressed Air Connections."

Final Checks

- Verify that all connections are secure and leak-free.
- Perform a pressure test according to system specifications before commissioning.
- Ensure the valve operates smoothly and without obstruction.

SAFETY WARNINGS AND PRECAUTIONS

- Installation must be carried out by qualified personnel only.
- Ensure the system is depressurized and free of hazardous substances before starting.
- Do not use the valve in applications exceeding its pressure, temperature, or chemical compatibility limits.
- Avoid excessive mechanical stress during installation to prevent damage or leaks.